

Novopeldaño[®] 4 Stainless Steel

h: 11 mm.

a: 25 mm

Length: 100/250 cm

Material: Stainless Steel

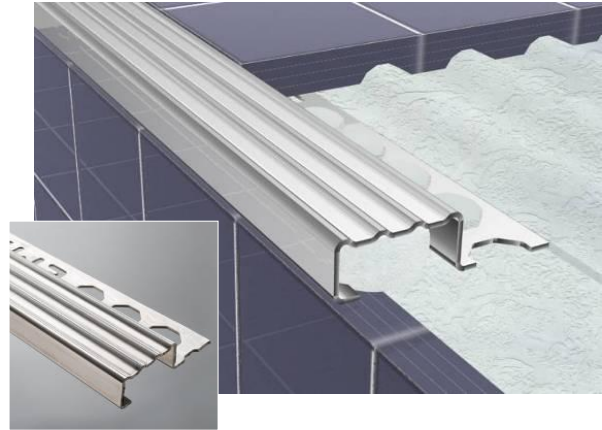
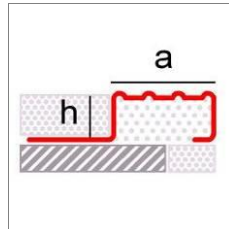

NOVOPELDAÑO[®] 4

Profile made of AISI 304 Stainless Steel used to decorate and protect tiled steps with ceramic tiles or any other material.

Its physical characteristics offer a high slip resistance necessary to properly develop its function.

Novopeldaño[®] 4 Stainless Steel has an exclusive treaded surface with a double mechanized with 4 bands of nonskid lines.

The fixing wings have an octagonal hole to make possible the transfer of the fixing material, guarantying an optimal installation and life

PROPERTIES OF STAINLESS STEEL

Characteristics

- Emac[®] profiles are made of with AISI 304 Stainless Steel, austenitic steel with an IIID surface and a protective layer resistant UV according to EN 10088-2 and EN 10259, EN 1.4301.
- Its excellent appearance and its high resistance to characterize stainless steel, which provides profiles qualities and a high durability to withstand the weather without

imperfections. The stainless steel will not darken over time.

- This is a material recommended for public establishments, for its extreme chemical and mechanical strength. Very popular in the current construction, fulfilling the expectations of architecture more demanding.

Mechanical Properties

- Good resistance to corrosion and atmospheric oxidation due to the ownership of these alloys to create a protective layer in the presence of an oxidizing environment. The formation of a chromium oxide film distributed uniformly throughout the material surface, invisible and strongly adhering to it, which is capable of self-regenerate if he loses his serve for the protection of stainless steel.

Thus stainless steels can maintain their corrosion resistance, even if they had been produced mechanical damage (eg, scratches, bumps, abrasion, cutting or machining), and to count as well with its own system of self-protection of repairer to corrosion:

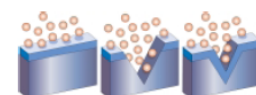

- It has a high mechanical strength, to shocks and structural stability.
- Its high tensile strength and impact resistant that may arise dents or grated. No scale

CORROSION RESISTANCE TEST

Stainless steel Emac[®] profiles have been tested in **Natural Salt Spray test** by the metal-mechanic technological institute AIMME, according to the UNE 112017:92 (ISO 9227:90).



Samples responded positively. After more than 500 hours of exposure, there were no changes in the samples.

Fire Resistance

Fire resistance classification as **A1** according to the current standard UNE EN 143501-1:2007. This classification corresponds to the class as **M0** according to NBE-CPI-96 (in accordance with the previous standard UNE 23727:1990), corresponding to a non-combustible material against the thermal action.

SLIP RESISTANCE TEST

Novopeldaño[®] 4 of Emac[®] has been subjected to slip resistance tests by Technological Institute of Construction AIDICO according to the Building Technical Code (CTE).

These tests confirmed the improved of the anti-slip degree (Rd) in groups formed with Novopeldaño[®] and tiles with different degrees of Rd.



ENTIDAD ASOCIADA A:



CHARACTERIZATION OF THE SLIP RESISTANCE

Rules

Ceramic tiles are subject to the requirement of the Basic Document DB-SU, Safety in use, SU1: Security against the risk of falls, belonging to the Technical Building Code (CTE).

Objetc

The object of the basic requirement "Safety in use" is to reduce, to acceptable levels, the risk for users of a building to suffer damaged during its foresee use, because of the nature of their design, construction, use and maintenance.

The CTE was approved by Royal Decree 214/2006, published in the Spanish Official Gazette (BOE) on March 28, 2006 and amended by Royal Decree 137/2007 on October 19, 2007, published in the BOE on October 23, 2007.

DB-SU 1: Security opposite the risk of fall demands limiting the risk that users have a fall, for which the floor should be suitable to favor people not slipping, tripping or limits its mobility.

Scope application

The conditions established by the DB-SU 1 apply floor building or area of use:

- Health: clinics, hospitals, health centers ...
- Teacher: universities, colleges, schools ...
- Commercial: markets, shopping malls, supermarkets, shops...
- Administrative offices, banks...
- Parkings
- Public use: Cultural building or establishment, (restaurants, shows, meeting, enjoyment, sport halls, gambling and similar), religious and passenger transport.

The *Restricted Use Areas* are excluded from these demands (Use zones or circulation elements limited to a maximum of 10 people who have the character of regular users, including inside homes, but excluding common areas of buildings housing).

The CTE does not expressly include the areas of Housing Residential Use and Public Residential Use, so these cases are under the demands of regulatory authorities, whether regional or municipals. In most cases the territorial regulations includes the areas of residential use in the scope of the CTE.

Housing Residential Use

Building or area for permanent accommodation, whatever the type of building: Single family housing, apartment building or flats, etc.

Public Residential Use

Building or facility designed to provide temporary accommodation, run by a titular of the activity different of the occupants group and can provide common services such as cleaning, dining, laundry, meeting facilities and entertainment, sports, etc.. Includes hotels, hostels, guest houses, pensions, apartments, etc...

Floor classification according to their slip

Slip resistance (Rd)	Type
$Rd \leq 15$	0
$15 < Rd \leq 35$	1
$35 < Rd \leq 45$	2
$Rd > 45$	3

Minimum type demanded in stairs and surfaces with slopes greater than 6 % by location.

Location	Type
Dry interior areas	2
Wet interior areas, such as building entrances from outer space (1), covered terraces, changing rooms, showers, bathrooms, aseos, cocinas, etc...	3
Interior areas where, in addition to, may be agents (fats, oils, etc..) to reduce slip resistance, such as industrial kitchens, abattoirs, car parks, industrial zones, etc..	3
Exterior areas. Swimming pools (2)	3

(1) Except in the case of access to restricted use zones.

(2) In areas predicted for users barefooted and in the bottom of basin pool, in areas where the depth does not exceed 1.5 m.

Test standard

The value of slip resistance is determined by the pendulum test, described in Annex A of the UNE-ENV 12633:2003 standard, using the C scale on test pieces without accelerated wear.

The Novopeldaño[®] 4 characterization was performed using the same procedure by which it is determinate, according to the CTE, the slip resistance of ceramic tiles, always taking as representative that one with the most unfavorable slip conditions.

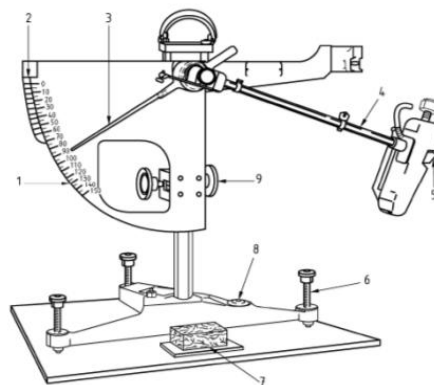

Data obtained

Most of tested surfaces together Novopeldaño[®] 4 improves its slip resistance value, even including the surface in a higher class as can be seen in the following graph:

Slip performance Novopeldaño[®] 4 Stainless Steel

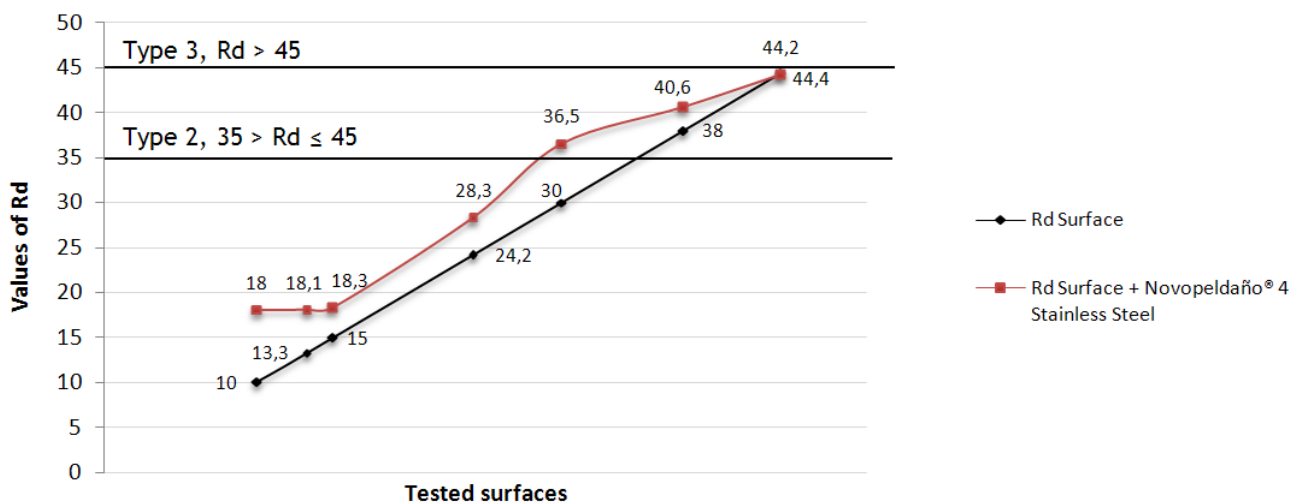

PLACEMENT

1. First extend abundant material grip on the stair pan where we will place the profile.
2. Put the pavement in the riser.
3. Then, align the profile on the step's vertex, resting on the riser, not to leave the profile without support.

Push the profile to ensure the perfect fixing, making sure that the material grip pass through the die, for that purpose.

4. Put the pavement on the wing fixing.
5. Finally, clean carefully the possible remnants of fixing material to prevent loss of appearance.



Placement example of a Novopeldaño[®] model

COMPLEMENTARY PIECES



The Novopeldaño[®] 4 Stainless Steel has complementary pieces available. With them is possible to achieve a perfect final touch and finish off, avoiding to make the angle. These pieces are corner and cover.

They are made of AISI 304 Stainless Steel and it is offered in the same finished than the profile to complements.



For the placement of the corner piece can be used the same fixing material that used to the tiled.

We recommend putting abundant fixing material into the piece and in the fixing wings. The material will support the pieces while facilitating a greater fixation.

For placement of the cover can be used the same fixing material or if the piece is placed after finishing the work, can be fixed with silicone.

It is very important to clean stains of fixing material to avoid loosed of appearance.

CLEANING AND MAINTENANCE

The first step in the maintaining of appearance of this material is offered by Emac[®], protecting their stainless steel profiles with a protective film, which will protect until the end of the installation.

INITIAL CLEANING

- The stainless steel requires a minimal maintenance. In principle, a correct cleaning will be sufficed to retain the aesthetic appearance of stainless steel.
- We recommend the **immediate cleaning** material fixing at the time of placement to avoid appearance loss. The mortar remains, cement and iron particles from scouring and tools, they can cause corrosion pitting.
- Cleaning can be done with water and/or liquid for dishes, liquid soap or detergent. It is also possible, do it with pressurized water or steam. It recommends regular cleaning of the product once a month. **Important:** To keep a good aspect, it must be dried immediately after rinsing, if not, the water spots will deposit and will ultimately tarnish.

MAINTENANCE

* Exterior Applications

In exterior applications, such as outsides, rainfall are a efficient cleaner opposite accumulations of dirt and other deposits, depending on the amount of material exposed in the building.

As for cleaning, special attention should be given in protected areas or difficult access during the cleaning, to make sure that all traces of dust or other elements are eliminated. This is particularly important in saline and industrial

environments, where the concentration of Chlorides SOx and the vast accumulation of particles in suspension may lead to localized corrosion if they are not removed effectively.

The frequency of cleaning depends on the environment that is exposed, but a good practice would be clean elements of stainless steel with the same frequency as the windows of the building.

🏠 Interior Applications

The primary care to be taken, on stainless steel place in interior applications, is the digital brands. Brushed aluminium is less sensitive to the fingerprints marks, though both are a wise

choice for interiors. Possible finger marks that can arise during installation will disappear after the material cleaning with water and/or liquid for dishes, liquid soap or detergent.

In the case of Mirror finishes can be cleaned with a crystals-cleaner, providing they are free of chlorides.

PRODUCTS TO AVOID

Cleaners

- **Abrasive products:** powdered abrasive cleaners (for example, VIM) can leave scratches.
- Cleaning products containing **hydrochloric acid** corrode stainless steel. Chlorine can attack the stainless steel, and can stain it. Chlorine can be used, but it should not keep in contact with stainless steel for a long time, only needed to fulfil its role disinfectant. For this reason cleaning products containing bleach (sodium hypochlorite) can damage if they are highly concentrated or remain in contact with surfaces for a long time. Salt and other cleaners containing chlorides can also cause damage. Dilute always these products "disinfectant"

Curing Accelerators with Chlorides

- The curing accelerators additives for mortars often contain chlorides. If you are going to put a stainless steel profile make sure that these accelerators **NOT CONTAIN CHLORIDES**, because will produce the oxidation of the material

Utensils

- Never use metal scourers, steel wool (like wool wire) or brushes wires, as well as scratching the surface of metal can leave metallic deposits on stainless steel, they can cause pitting corrosion.
- Never use wool scouring carbon steel. Usual "steel" cleaners (for example shine scouring) are not suitable either for stainless

CONDITIONS TO AVOID

- Do not place the material into prolonged contact with iron products, since it is possible to generate galvanic corrosion. If the material is going to be in contact with other metal parts, be sure to place non-metallic barrier between both. In case of placing fixation systems, is

There are products on the market for the maintenance of stainless steel, which remove these finger marks, keep the bright of the stainless steel and reduce the tendency of the emergence of these brands.

when used, reducing the exposure time to a minimum and clarifying the surface thoroughly with abundant clean water.

- The **silver cleaners** may contain chlorides and strong acids, and are therefore not suitable for stainless steel, since the protective layer of stainless steel may be affected by some acids; giving rise to the iron is oxidized and attacked by mechanisms inter-crystalline or widespread pitting.
- Whenever you use any acid or solvent, rinse well with neutral water.

by inter-granular mechanisms or widespread bites.

- There are special versions on the market without chlorides to prevent corrosion of metals.

steel, since it eliminated its protective layer and even reduce the surface self-repairing ability.

- Do not use materials containing chlorides.
- To avoid "cross-contamination" by iron particles to avoid that the utensils destined to the cleaning of the stainless steel are also used for the cleaning of the ordinary steel (to carbon).

highly recommended that also are also of stainless steel.

- There will be certain conditions under which they miss the "passive state" that protects the material from corrosion and cannot be retrieved. In this case, the surface becomes

"active" and corrosion occurs. These areas may be active in small areas deprived of oxygen of stainless steels, as in mechanical joints, compact corners or incomplete or poorly finished welds. The result may be "localized" areas of crack or pits. These active areas by lack of oxygen may arise after a damaged of the material and a deposition of dirt that prevents surface contact with environmental oxygen, avoiding that can form new protective layer. These less airy areas act as anode, rusting the material which is in contact.

- To avoid this, clean very well the material and dry it, so as not to accumulate the dirt or other material remnants that can avoid self-repair of this protective layer. To avoid this, clean very well the material and dry it, so as not to accumulate the dirt or other material remnants that can avoid self-repair of this passive layer. If the oxide layer was form, will be necessary sanding the surface to remove it, clean and dry it to encourage the formation of the new protective layer or treat the surface with a nitric acid solution.

SOLUTIONS OF POSSIBLE DEFECTS AND TECHNIQUES TO ELIMINATE

- Dust and dirt: Wash with water and / or detergent. If necessary, do it with pressurized water or steam.
- Persistent Stains: The application of soft creams designed to smooth household cleaning should be sufficient. After cleaning, dispose of the waste with water and dry well to avoid streaks and/or water marks. Do not use cleaners or polishing powder because they may scratch the surface of stainless steel.
- Iron particles inclusions: Treat the surface with nitric acid solution to 20%. Rinse with clean water. Confirm elimination with the ferroxile test. If the iron is still present, using a solution of nitric acid and hydrofluoric acid.
- Mortar remains and cement splashes: Treat with a solution containing a small amount of phosphoric acid, then rinse with water and dry very well.
- Scratches, warming stains: Polish the surface with a fine abrasive. Strip the surface with a nitric acid solution to 10% and hydrofluoric acid solutions to 2% to eliminate all traces. Rinse with clean water or electro-polish.
- Rusty Area: Treat the surface with a solution of nitric acid.
- Rug: Polish with a fine grain abrasive.
- Welding splashes: to prevent it using a film adhesive to the welding cord sides, or eliminate them using a fine-grained abrasive.
- Welding flux marks: Remove through fine-grain abrasive.
- Oil and fat: Remove with solvents or alkaline cleaners and rinse with abundant neutral water.
- Stickers waste: Remove with solvents or polished with fine-grain abrasive.
- Paint, chalk and crayon: Rinse with clean water and / or alkaline cleaners.



Dry very well after cleaning, especially in areas where the water is very hard. If is possible, preferably use de-ionized water (it is available in supermarkets for use on irons or batteries for cars) because it decreases the risk of stains by etching.

TECHNICAL INFORMATION



You can download more information about the technical characteristics of the material that the Novopeldaño[®] 4 is made

of in www.emac.es

If you have some query or question, please contact with the technical office: otecnica@emac.es